

VOIDED SLAB DESIGN¹

First draft June 8, 2011

1 – VOIDED SLABS

Voided slabs are an alternative to waffle floor construction, where unlike the waffle alternative the soffit of the cast floor is solid. Depending on the anticipated finish of a floor's soffit, a solid alternative can be advantageous.

Figures 1-1; and 1-2 illustrate two commercially available styles of voided slab construction.

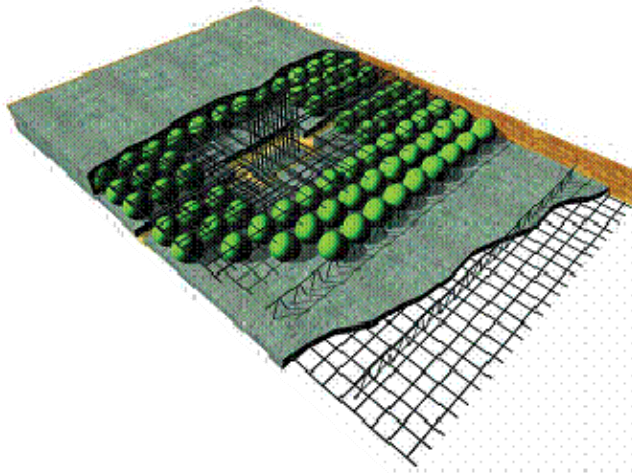

(a) Elements of a voided slab construction

(b) View of a voided slab in construction

FIGURE 1-1 Voided Slab Construction Using Pre-assembled Spheres



(a) View of a void insert

(b) Construction view

FIGURE 1-2 Example of a Post-Tensioned Voided Slab Construction

¹ Copyright ADAPT Corporation 2011

There are other schemes of creating voids in concrete for reduction of weight, or savings in cost of concrete material. Figure 1-3 illustrates the application of large Styrofoam blocks in achieving voids in slab.



FIGURE 1-3 Application of Styrofoam Blocks to Create Voids in a Slab

This Technical Note describes the structural modeling, analysis and design of voided slabs, of the type that is illustrated in Fig. 1-1 and 1-2, using the Builder Floor Pro computer program. The typical elements a voided slab are shown in Fig. 1-4.

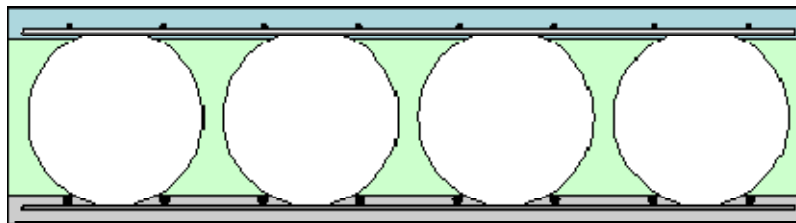
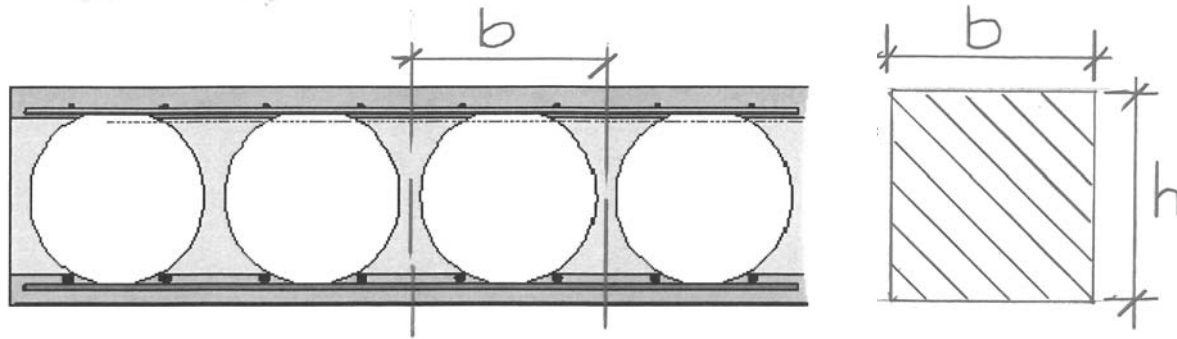

FIGURE 1-4 Elements of a Voided Slab Construction

It is important to note that at this time, there are no commercially available software that cover the entire spectrum of modeling, analysis and design of a floor system constructed with voided slabs. For conventionally reinforced floor systems (RC), the computer program Floor Pro can model, analyze and design a voided slab with authenticity. For post-tensioned floors, however, at this time the modeling and design involves a degree of approximation. Both options are described next.

2 - CONVENTIONALLY REINFORCED VOIDED SLABS

The two central considerations in design of conventionally reinforced (RC) slabs are (i) deflection control and (ii) provision of reinforcement for safety of the structure – namely, the strength design. At analysis and design stage, the two requirements can be met, if the voided slab region of a floor system is substituted by an equivalent slab of uniform thickness as outlined in Fig. 2-1b, with properties modified to represent the response of its prototype. The following describes the properties of the substitute slab.



(a) Elements of a voided slab

(b) Solid equivalent of a typical unit

FIGURE 2-1 Elements of a Voided Slab and its Equivalent Solid Representation

The equivalent slab has the same depth “h” as the original slab, but a modified property. Table 2-1 lists the modeling parameters of the equivalent slab in relation to its voided counterpart. The background to the equivalency is described in the following:

TABLE 2-1 Parameters of Equivalent Solid Slab for Conventionally Reinforced Slabs

Parameter	Voided slab	Equivalent slab
Depth	h	h
Width	b	b
Concrete strength	f’c	f’c
Unit weight	W	W _e
Modulus of Elasticity	E	E _e = 12*E*I / (b*h ³)

2.1 Selfweight

On account of the voids, a new concrete material must be defined in Builder Floor Pro with unit weight (W_e) adjusted to reflect that of the solid equivalent slab.

2.2 Deflections (SLS)

For the same span arrangement and boundary conditions, the deflection of a slab is governed by the stiffness of the slab expressed by the product of modulus of elasticity (E) and the second moment of area (I), namely (E*I). For equivalent deflection response, the following governs:

$$E*I = E_e * b h^3 / 12$$

Where, the suffix (e) is specific to the equivalent slab

Hence:
$$E_e = 12 * E * I / (b * h^3)$$

2.3 Strength (ULS)

The amount of reinforcement calculated to resist the demand moment depends on the width of the section (b), depth of the section (h), and the concrete strength (f'c). It is assumed that the compression zone will be limited to the solid portion of the voided slab. Hence, for practical purposes, the reinforcement calculated for the equivalent slab described in 2-1 will apply to the prototype voided slab too.

2.4 One-way Slab Shear

The proposed equivalent model has a somewhat larger one-way shear capacity than the prototype. However, one-way shear is considered not to be critical in floor systems of common geometry and loading.

3 – POST-TENSIONED SLABS

The voided slab construction, as illustrated in Fig. 1-1 does not lend itself to easy installment of post-tensioning tendons, since the hollow spheres are generally pre-assembled in a cage with a reinforcement mesh on the top and bottom of the multi-sphere arrangement. Post-tensioned tendons have to be woven through the cage for installation. Since, to accommodate top and bottom added reinforcement, the depth of the cage is typically much smaller than the depth of the slab, an optimum drape for tendons placed within the cage cannot be achieved.

One alternative is to group the tendons in one direction within the solids strips (Fig. 3-1) between the column supports, and reinforce the slab in the orthogonal direction using conventional reinforcement. Current ACI-318-11, does not permit the tendons to be limited to groups in both directions, but the layout is practiced in other parts of the world, where ACI-318 does not govern.

The design of a post-tensioned slab includes crack control, in addition to deflection control and provision of reinforcement for safety. Using ACI 318, the crack control is achieved through limits imposed on hypothetical extreme fiber tensile stresses.

Application of Floor Pro computer program and the modeling scheme proposed above for conventionally reinforced slabs accounts for the deflection and strength requirements of the slab, as well as for stress values of solid regions shown in Fig. 3-1. For the voided construction at the interior of the panels, the values obtained are on the low side. The substitute model has a larger cross-sectional area and section modulus, both of which will result in lower computed stresses.

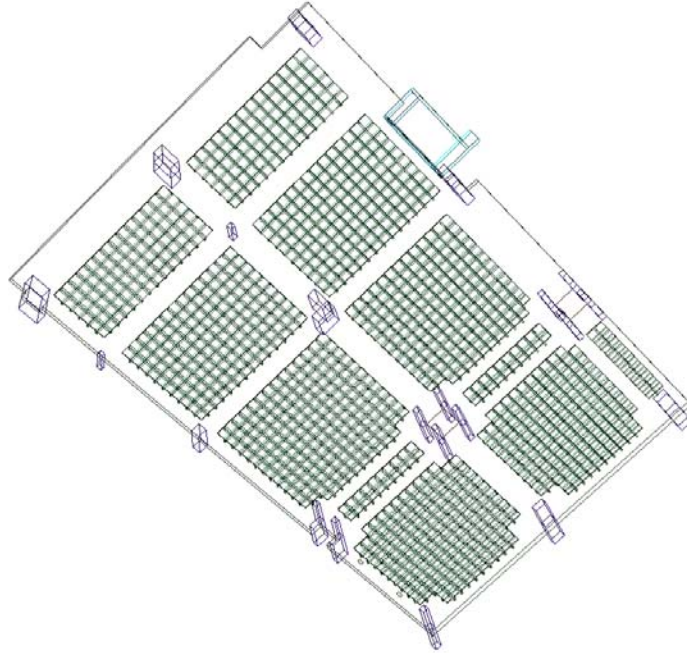

FIGURE 3-1 Voided Slab or Waffle Construction with Solid Bands Between Supports

For design, it is recommended to use the code-stipulated limit of allowable stress for solid regions, but a smaller value for the voided sections. Recognizing that in designs based on ACI-318, (i) the stress due to axial compression from prestressing is typically one third of the value from bending, and (ii) the axial compression for the solid region is typically maintained at 1 MPa, one may arrive at what would be an acceptable range of fiber stress in the voided regions, the keep the stresses within the code limits.

An alternative to the above is to view on the computer screen the reported values of the axial force and moment at design time and using a spread sheet convert them to the values of the actual voided slab unit to arrive at the stresses in the prototype.